



Serving the Gas Industry Worldwide

BD USA MODEL
200

SPRING-LOADED GAS PRESSURE REGULATOR

Technical Manual



MODEL 200 GAS PRESSURE REGULATOR



General Description

Applications

- Primarily utilized for residential, commercial and industrial applications
- Generally utilized for farm tap or rural installations, by-pass regulator for pressure reducing stations or high pressure, first-cut regulator applications
- For natural gas and all non-corrosive gaseous media
- Various options for specialty applications

Characteristics

- Specifically designed for safe, accurate, pressure reduction of gaseous media
- Wide inlet pressure range 5–1000 psig (0.35-68 bar) depending on orifice diameter
- Maximum inlet pressure 1000 psig (68 bar)
- Maximum operating pressure 1000 psig (68 bar)
- Spring-loaded, lever-operated to accommodate changes in inlet pressure
- Various interchangeable orifices for ease of maintenance and increased turndown ratio to accommodate a wide range of flows and pressure conditions (inlet & outlet pressures)
- Outlet pressure settings from 3 psig to 150 psig (0.21 to 10 bar) over 7 spring ranges
- 2 different inlet/outlet thread diameters (National or British Pipe Standards – NPT, BSPT, BSPP)
- 2 relief valve assemblies available (full and zero capacity relief discharge)
- 1/2" threaded vent connection supplied with aluminum vent fitting
- Available with Internal Impulse or Control Line (I.C.L.) or External Impulse or Control Line Connections (E.C.L.)
- Ease of maintenance due to interchangeable diaphragm casing cartridge accessible via a union nut to the body
- Various safety slam-shut valve (SSV) models available for pressure/flow cut-off protection
- Custom designed and pre-fabricated regulator assemblies available

MODEL 200 GAS PRESSURE REGULATOR



General Description

◇ Outlet pressures from 3 to 150 psig over 7 spring ranges. Set point can be adjusted easily with standard adjustable wrench. Regulator top cap has the capability of including the provision for a wire seal.

◇ 1/2" threaded vent connection protected by screen that is easily removed to attach vent extender or vent-line.

◇ Reinforced diaphragm for increased speed of response and durability.

◇ Available with full capacity, limited capacity, no capacity internal relief valve designs to manage the capability of the regulator to discharge over pressure gas. Safety diaphragms also available.

◇ Available with Internal Impulse or Control Line (I.C.L.) or External Impulse or Control Line Connections (E.C.L.)

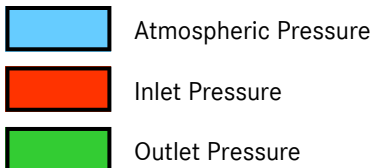

◇ Over Pressure Safety Slam-Shut Valve (OPCO) options available

◇ Under & Over Pressure Safety Slam-Shut Valve (UPCO/OPCO) options available

◇ Over Pressure Safety Slam-Shut Valve (OPCO) option only available up to 66 psig (4.5 bar) cut-off set pressure.

◇ Integral slam-shut valves available to protect against under (UPCO) and over pressure (OPCO) conditions in the downstream pipe-work. Slam-shut valves also available with low differential pressure cut-off and thermal trip (T-type) protection feature to shut gas off if regulator is engulfed in a fire.

◇ Pressure test points available at inlet & outlet chambers of the body, as an option.

◇ Several available orifice diameters to accommodate a wide range of pressure conditions and flow require-

◇ 2 different pipe thread diameters available on an inline (180°) body designs with 3/4", 1" NPT, BSPT or BSPP.

◇ Cartridge style regulator diaphragm casing design with so retrofitting new regulator casings is very easy without removing regulator body from the pipe-work.

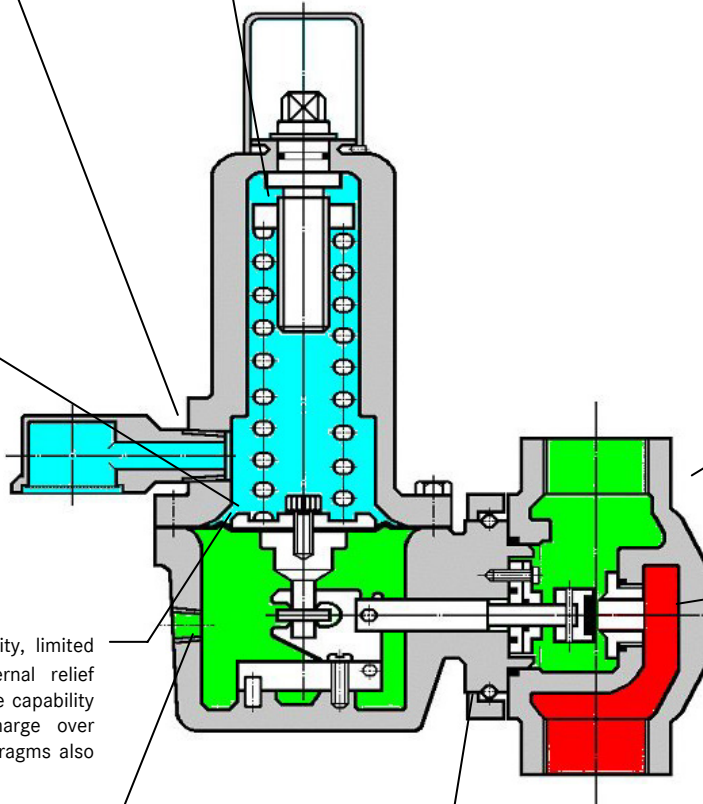
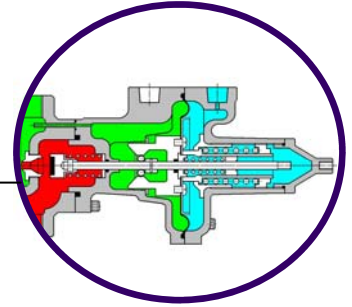

MODEL 200 GAS PRESSURE REGULATOR



General Description

Available Constructions

200 R: full internal relief capacity

200 P: no internal relief capacity

200R-309 OPCO: full internal relief capacity with integral Over Pressure Cut-Off safety slam-shut valve

200P-309 OPCO: no internal relief capacity with integral Over Pressure Cut-Off safety slam-shut valve

200R-309 UPCO/OPCO: full internal relief capacity with integral Under and Over Pressure Cut-Off safety slam-shut valve

200P-309 UPCO/OPCO: no internal relief capacity with integral Under and Over Pressure Cut-Off safety slam-shut valve

Thermal Protection (T-Type): full or no internal relief capacity with safety diaphragms and integral safety slam-shut valve (OPCO or UPCO/OPCO) that has shut-off protection if assembly is engulfed in a fire. Assembly has many steel component parts.

I.C.L. Type: Internally sensing or internal control line to measure outlet pressure

E.C.L. Type: Externally sensing or external control line required to measure outlet pressure in downstream pipe-work. Diaphragm casings drilled and tapped 1/2" NPT or BSPT to connect downstream sensing line.

F version: complete with inlet mess filter

Body Sizes and Connection Types

Inline Screwed Type Body

- 3/4" or 1" screwed
- NPT, BSPT or BSPP threaded types

Temperature Rating

- -40° to 60° Celsius
- -40° to 140° Fahrenheit

MODEL 200 GAS PRESSURE REGULATOR



General Description

Pressure Ratings

Maximum Recommended Inlet Pressure

- 1000 psig (68 bar)

Maximum Recommended Operating Pressure

- 1000 psig (68 bar) with 1/8" (3.2mm) orifice
- 1000 psig (68 bar) with 3/16" (5.0mm) orifice
- 500 psig (34 bar) with 1/4" (7.0mm) orifice
- 300 psig (20.4 bar) with 3/8" (9.0mm) orifice
- 200 psig (13.6 bar) with 1/2" (12.5mm) orifice

Materials of Construction

Body	Cast Iron
Diaphragm Casings	Cast Iron
Diaphragm	Nitrile Rubber with Nylon Reinforcing
Valve Head (Seat)	Polyurethane
Spring Carrier	Plated Steel
Orifice (standard)	Brass
Orifice (optional)	Stainless Steel
Vent Screen	Stainless Steel
Fasteners	Steel
Top Cap (standard)	Cast Iron

Weights

- w/ screwed body (3/4" & 1") – 14 lb. (6.4 kg)
- w/ 309 LP4 – add 5.0 lb. (2.3 kg)

MODEL 200 GAS PRESSURE REGULATOR



General Description

Outlet Pressure Range

Range (imperial)	Range (metric)	Spring Number/Colour
3 – 10 psig	0.35 – 0.70 bar	1030 (brown)
8 – 20 psig	0.56 – 1.4 bar	1031 (green)
15 – 25 psig	1.0 – 1.7 bar	1032 (blue)
20 – 40 psig	1.4 – 2.7 bar	1033 (silver)
30 – 75 psig	2.0 – 5.1 bar	1036 (red)
50 – 100 psig	3.4 – 6.8 bar	1037 (white)
80 – 150 psig	5.4 – 10.2 bar	1034 (yellow)

Relief Pressure Range

Outlet Pressure Spring	Relief Range (imperial)	Relief Range (metric)
1030	13 – 22 psig	0.88 – 1.5 bar
1031	18 – 32 psig	1.2 – 2.2 bar
1032	28 – 40 psig	1.9 – 2.7 bar
1033	35 – 58 psig	2.4 – 3.9 bar
1036	45 – 100 psig	3.1 – 6.8 bar
1037	65 – 120 psig	4.4 – 8.2 bar
1034	100 – 175 psig	6.8 – 11.9 bar

Relief Valve Options

Full Internal Relief
(R-Type)

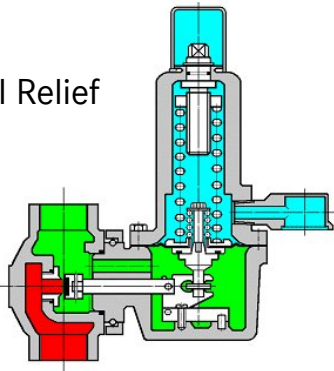

No Internal Relief
(P-Type)

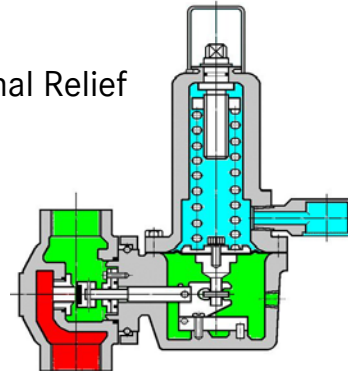

MODEL 200 GAS PRESSURE REGULATOR



General Description

Performance Capacity

Outlet Pressure	Differential Pressure		Orifice Size (millimeters/inches)									
	psig	bar	1/8" (3.2mm)		3/16" (5.0mm)		1/4" (7.0mm)		3/8" (9.0mm)		1/2" (12.5mm)	
SPRING 1030 Brown Range 3-10 psig 0.21-0.68 bar Accuracy Class 20%	20	(1.4)	1200	(34.0)	1300	(36.8)	2800	(79.3)	3200	(90.7)	4200	(119.0)
	50	(3.4)	1400	(39.7)	1600	(45.3)	3100	(87.8)	3500	(99.2)	4800	(136.0)
	100	(6.8)	1700	(48.2)	1900	(53.8)	3600	(102.0)	4100	(117.1)	5600	(158.6)
	200	(13.6)	2400	(68.0)	2700	(76.5)	4600	(130.3)	5400	(153.0)	7600	(215.3)
	300	(20.4)	3100	(87.8)	3400	(96.3)	5700	(161.5)	6700	(189.8)		
	400	(27.2)	3800	(107.6)	4200	(119.0)	6600	(187.0)				
	500	(34.0)	4500	(127.5)	5000	(141.6)	6800	(192.6)				
	750	(51.0)	5200	(147.3)	6800	(192.6)						
1000	(68.0)	7700	(218.1)	6800	(192.6)							
SPRING 1031 Green Range 8-20 psig 0.5-1.4 bar Accuracy Class 20%	20	(1.4)	1300	(36.8)	5900	(167.1)	6800	(192.6)	4800	(136.0)	5700	(161.5)
	50	(3.4)	1500	(42.5)	6100	(172.8)	7000	(198.3)	5200	(147.3)	6400	(181.3)
	100	(6.8)	1800	(51.0)	6300	(178.5)	7300	(206.8)	5900	(167.1)	7500	(212.5)
	200	(13.6)	2700	(76.5)	6800	(192.6)	7800	(221.0)	7000	(198.3)	9600	(272.0)
	300	(20.4)	3500	(99.2)	7200	(204.0)	8400	(238.0)	8300	(235.1)		
	400	(27.2)	4300	(121.8)	7600	(215.3)	8900	(252.1)				
	500	(34.0)	5100	(144.5)	7900	(223.8)	9600	(272.0)				
	750	(51.0)	7000	(198.3)	9100	(257.8)						
1000	(68.0)	8800	(249.3)	9700	(274.8)							
SPRING 1032 Blue Range 15-25 psig 1.0-1.7 bar Accuracy Class 20%	20	(1.4)	1700	(48.2)	5300	(150.1)	6500	(184.1)	7800	(221.0)	8700	(246.5)
	50	(3.4)	2000	(56.7)	5600	(158.6)	6700	(189.8)	8100	(229.5)	9000	(255.0)
	100	(6.8)	2700	(76.5)	5900	(167.1)	7000	(198.3)	8400	(238.0)	9350	(264.9)
	200	(13.6)	3900	(110.5)	6700	(189.8)	7600	(215.3)	8900	(252.1)	11000	(311.6)
	300	(20.4)	5200	(147.3)	7600	(215.3)	8300	(235.1)	9600	(272.0)		
	400	(27.2)	6500	(184.1)	8300	(235.1)	8800	(249.3)				
	500	(34.0)	7700	(218.1)	9100	(257.8)	9600	(272.0)				
	750	(51.0)	11000	(311.6)	12000	(339.9)						
1000	(68.0)	14000	(396.6)	16000	(453.2)							

Scfh (ft³/hr) - natural gas, 0.6 sg
 Scmh (m³/hr) - natural gas, 0.6 sg

MODEL 200 GAS PRESSURE REGULATOR



General Description

Performance Capacity

Outlet Pressure	Differential Pressure		Orifice Size (millimeters/inches)									
	psig	bar	1/8" (3.2mm)		3/16" (5.0mm)		1/4" (7.0mm)		3/8" (9.0mm)		1/2" (12.5mm)	
SPRING 1033 Silver Range 20-40 psig 1.4-2.7 bar Accuracy Class 20%	20	(1.4)	600	(17.0)	4400	(124.6)	6600	(187.0)	7400	(209.6)	9300	(263.4)
	50	(3.4)	1000	(28.3)	4900	(138.8)	7000	(198.0)	7700	(218.1)	11000	(311.6)
	100	(6.8)	1800	(51.0)	5700	(161.5)	7900	(223.8)	8100	(229.5)	12000	(339.9)
	200	(13.6)	3400	(96.3)	7000	(198.3)	9600	(271.9)	9500	(269.1)	14000	(396.6)
	300	(20.4)	5200	(147.3)	8800	(249.3)	12000	(339.9)	11000	(311.6)		
	400	(27.2)	6800	(192.6)	11000	(311.6)	13000	(368.3)				
	500	(34.0)	8600	(243.6)	12000	(339.9)	15000	(424.9)				
	750	(51.0)	13000	(368.2)	16000	(453.3)						
1000	(68.0)	16000	(453.3)	17000	(481.6)							
SPRING 1036 Red Range 30-75 psig 2.0-5.1bar Accuracy Class 20%	20	(1.4)	1400	(39.7)	2100	(59.5)	5000	(141.6)	7400	(209.6)	12000	(339.9)
	50	(3.4)	1700	(48.2)	2700	(76.5)	5200	(147.3)	7800	(221.0)	13000	(368.3)
	100	(6.8)	2300	(65.2)	3500	(99.2)	6300	(178.5)	9000	(255.0)	15000	(424.9)
	200	(13.6)	3000	(85.0)	5000	(141.6)	8000	(226.6)	12000	(339.9)	19000	(538.2)
	300	(20.4)	3900	(110.5)	6500	(184.1)	10000	(283.3)	14000	(396.6)		
	400	(27.2)	4700	(133.1)	8100	(229.5)	12000	(339.9)				
	500	(34.0)	5600	(158.6)	9600	(272.0)	13000	(368.3)				
	750	(51.0)	7700	(218.1)	14000	(396.6)						
1000	(68.0)	9800	(277.6)	15000	(424.9)							
SPRING 1037 White Range 50-100 psig 3.4-6.8 bar Accuracy Class 20%	20	(1.4)	1200	(34.0)	2400	(68.0)	4400	(124.6)	8600	(243.6)	11000	(311.6)
	50	(3.4)	1900	(53.8)	3800	(107.6)	4900	(138.8)	11000	(311.6)	14000	(396.6)
	100	(6.8)	2600	(73.7)	4900	(138.8)	5900	(167.1)	14000	(396.6)	19000	(538.2)
	200	(13.6)	4300	(121.8)	5900	(167.1)	6800	(192.6)	19000	(538.2)	29000	(821.5)
	300	(20.4)	5700	(161.5)	8200	(232.3)	10000	(283.3)	25000	(708.2)		
	400	(27.2)	7500	(212.5)	9200	(260.6)	13000	(368.3)				
	500	(34.0)	8900	(252.1)	14000	(396.6)	15000	(424.9)				
	750	(51.0)	13000	(368.3)	19000	(538.2)						
1000	(68.0)	16000	(453.3)	22000	(623.2)							

Scfh (ft³/hr) - natural gas, 0.6 sg
 Scmh (m³/hr) - natural gas, 0.6 sg

MODEL 200 GAS PRESSURE REGULATOR



General Description

Performance Capacity

Outlet Pressure	Differential Pressure		Orifice Size (millimeters/inches)									
	psig	bar	1/8" (3.2mm)		3/16" (5.0mm)		1/4" (7.0mm)		3/8" (9.0mm)		1/2" (12.5mm)	
SPRING 1034 Yellow Range 80-150 psig 5.4-10.2 bar Accuracy Class 20%	20	(1.4)	1700	(48.2)	4500	(127.5)	5900	(167.1)	19000	(538.2)	12000	(339.9)
	50	(3.4)	2200	(63.3)	5000	(141.6)	6800	(192.6)	20000	(566.6)	14000	(396.6)
	100	(6.8)	2800	(79.3)	5700	(161.5)	9000	(255.0)	22000	(623.2)	21000	(594.9)
	200	(13.6)	3800	(107.7)	7300	(206.8)	12000	(339.9)	26000	(736.5)	30000	(849.9)
	300	(20.4)	5100	(144.5)	8900	(252.1)	14000	(396.6)	31000	(878.2)		
	400	(27.2)	6400	(181.3)	11000	(311.6)	18000	(509.9)				
	500	(34.0)	7400	(209.6)	13000	(368.3)	20000	(566.6)				
	750	(51.0)	11000	(311.6)	16000	(453.3)						
1000	(68.0)	13000	(368.3)	18000	(509.9)							

Relief Valve Performance Capacity

Scfh (ft³/hr) - natural gas, 0.6 sg
Scmh (m³/hr) - natural gas, 0.6 sg

INTERNAL RELIEF VALVE PERFORMANCE						
SPRING COLOUR	OUTLET PRESSURE SET POINT psig	MAXIMUM OUTLET PRESSURE BUILD UP	INLET PRESSURE ORIFICE SIZE			
			1/8"	3/16"	1/4"	3/8"
			Brown	3 to 10	60	730
Green	8 to 20	60	730	200	110	65
Blue	15 to 25	60	730	200	110	65
		125	1000	360	200	145
Silver	20	60	730	200	110	65
	30	60	620	160	90	65
	40	60	500	140	80	65
	20 to 40	125	1000	360	200	145
Red	30	60	550	140	80	65
	40	60	570	150	100	85
	50	90	760	200	130	110
	60	100	800	210	130	115
	75	125	1000	240	160	125
	30 to 75	125	1000	360	200	145
Yellow	80	100	800	210	130	115
	50	150	950	420	250	175
	60	100	780	200	130	115
	60	150	950	400	240	175
	75	125	1000	240	160	135
	75	185	1000	520	310	210
	100	150	1000	280	200	160
	100	225	1000	540	350	250
White	50	175	1000	310	220	190
	100	200	1000	370	270	220
	125	250	1000	500	350	270
	150	285	1000	580	380	315



MODEL 200 GAS PRESSURE REGULATOR

General Description

Capacity Calculation or Correction Factors for Other Gases

<u>Gas Type</u>	<u>Specific Gravity</u>	<u>Correction Factor (CF)</u>
Air	1.00	0.77
Butane	2.01	0.55
Carbon Dioxide (Dry)	1.52	0.63
Carbon Monoxide (Dry)	0.97	0.79
Natural Gas	0.60	1.00
Nitrogen	0.97	0.79
Propane	1.53	0.63
Propane-Air-Mix	1.20	0.71

Vent and Body Orientations

Orientation – Body Position Letter followed by Vent Position Number

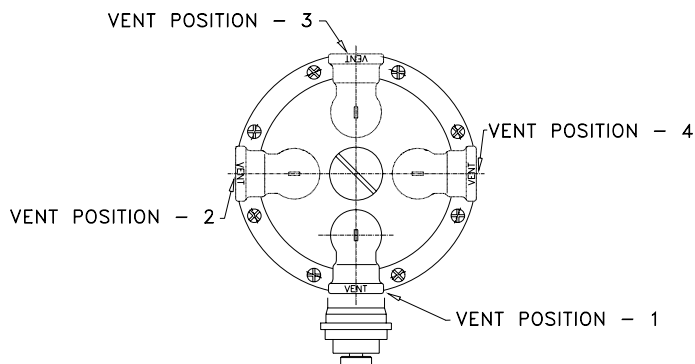

For Other Correction Factors

$$C_F = \sqrt{\frac{0.6}{\text{Sg of Gas}}}$$

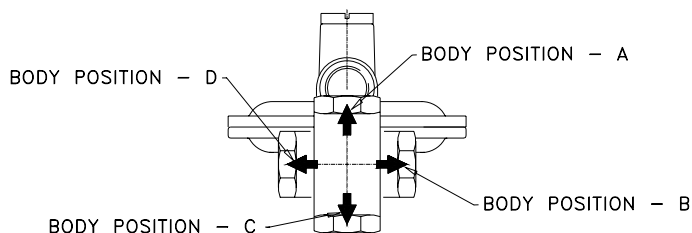

MATCH GAS FLOW INDICATING ARROW FOUND ON CASTING

MODEL 200 GAS PRESSURE REGULATOR

General Description



Sectional Diagrams

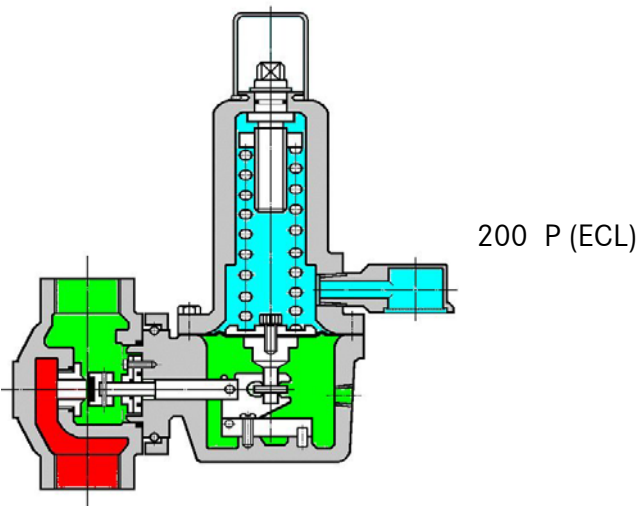
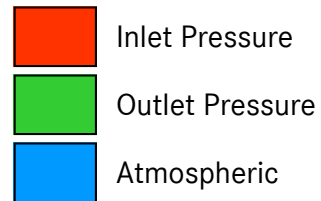

200 P (ICL)

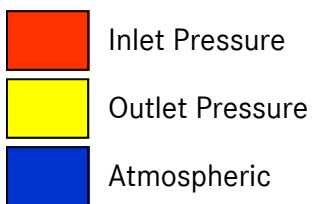
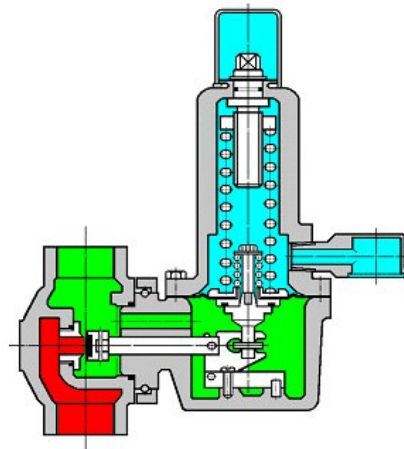

200 R – 309LP4 OPCO

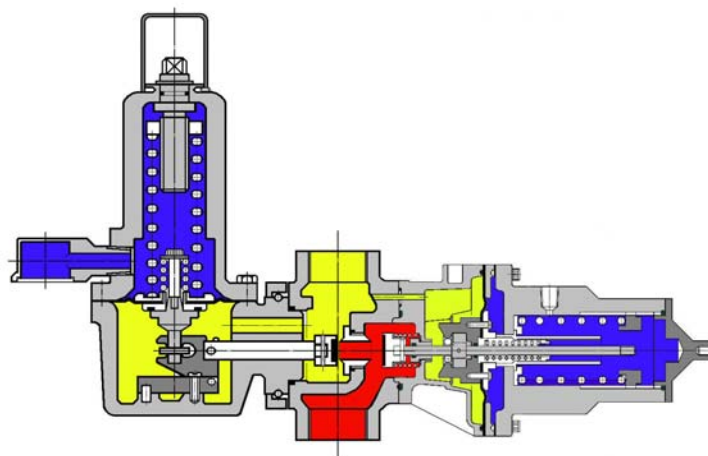



MODEL 200 GAS PRESSURE REGULATOR

General Description

Dimensional Drawings

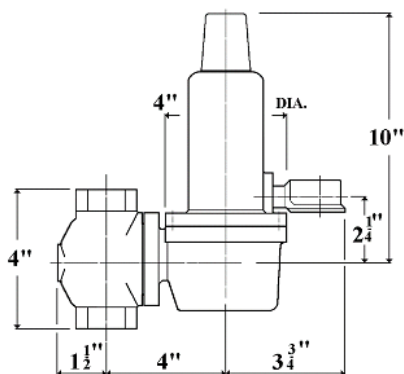

200 (P & R-Type)

Overall Length – 9.25"

200-309LP4 OPCO

Overall Length – 16"

External Control Line Versions (E.C.L.)

- Regulators with an external control line have the throat of the regulator blocked with a seal and the outlet pressure measuring chamber (lower diaphragm casing) drilled and tapped for an outlet pressure sensing line. It is recommended that the sensing point is a minimum of 5 times the outlet pipe diameter downstream of the regulator.
- Sensing outlet pressure via an external control line enables the regulator to respond more accurately to the downstream system.

Throat Seal

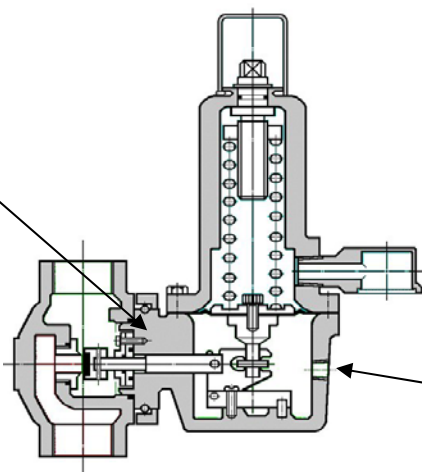

External Control Line Connection
(tapped 1/2")

Diagram of Regulator Station and Recommended Location of External Control Line (E.C.L.) Connections

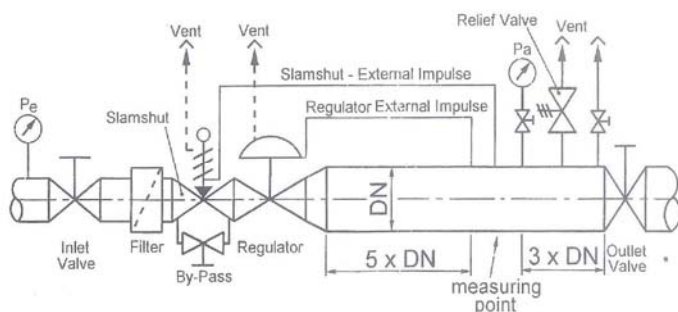

MODEL 200 GAS PRESSURE REGULATOR



General Description

Internal Relief Valve and Safety Slam Shut Valve Options

Regulators for Reduced Clearances or Venting Limitations

- Please contact one of our representatives for more detailed information

Regulators for Indoor Installations without Requirement for Vent-Line

- Please contact one of our representatives for more detailed information

Internal Safety Relief Valve (SRV) Description

- The SRV is designed to monitor the pressure in the outlet chamber or downstream of the regulator and to relieve by either venting gas leakages or full flow capacity (depending on the device design) into the atmosphere in the event of an over-pressure condition.
- If the pressure in the measuring chamber exceeds the force of the set point spring of the relief valve, the diaphragm rises and opens the relief valve. The gas then flows from the outlet pressure line to atmosphere or another desired location.
- The relief gas pressure and flow is discharged until the pressure is returned to the predetermined safe level.
- The safety relief pressure of the internal relief valve occurs slightly above the set pressure of the main spring or outlet pressure

Safety Slam Shut Valve (SSV) Description

- The SSV is designed to monitor the outlet pressure and to interrupt the gas flow, if preset limits are exceeded.
- This preset pressure is adjustable in the field.
- If the measured pressure reaches the set point of the SSV, a release mechanism is triggered and the SSV closes the valve on the inlet pressure side of the regulator. This closing function completely blocks the forward movement of gas past the SSV.
- Safety slam shut valves are available in over pressure cut off (OPCO) protection or under and over pressure cut off (UPCO/OPCO) protection.
- After the SSV is tripped, the condition that triggered the closing of the valve must be addressed and then the SSV can be manually reset.
- Thermal trip protection is also available as an option to shut the gas flow off, if the safety slam shut valve is exposed to high temperatures or engulfed in a fire (T-Type).
- Please contact one of our representatives for the technical brochure on all of our safety slam shut valves.

MODEL 200 GAS PRESSURE REGULATOR



General Description

Commissioning and Installation Instructions

Please contact one of our representatives for the installation and commissioning instructions. Additionally, the commissioning and installation instructions are found in each box that the equipment is shipped in and can be downloaded from the website.

Ordering Information

1. Inlet pressure (minimum and maximum)
2. Outlet pressure requirement
3. Flow requirement (minimum and maximum)
4. Type of gas
5. Temperature
6. Pipe connections (inlet and outlet)
7. Internal or external impulse (sensing)
8. Safety options or requirements (SRV and/or SSV)
9. Vent and body orientation
10. Other critical information (system design or description)

Product Portfolio

- Pressure regulators for every application from domestic, commercial, industrial to transmission line, city gate stations and other gas utility applications.
- Safety relief valves
- Safety slam shut valves
- Metering equipment (rotary displacement, turbine, vortex shedding, ultrasonic)
- Volume correctors (temperature and pressure)
- Filters
- Underground pressure regulator and metering modules
- Ball valves
- Station design and assembly (prefabricated stations, skid-mounted assemblies, small regulator/meter-set assemblies)
- Flame arrestors
- Data logging and software
- Check and non-return valves
- Training and after-sales service



BRYAN DONKIN is your worldwide partner for gas control equipment, ranging from exploration to consumer supply. The comprehensive range of BRYAN DONKIN products and systems provides you with a total solution for all your gas control and measurement needs.

Modern manufacturing techniques, combined with our expertise and specialist knowledge in the design and build of gas control equipment (including fully automated stations) has earned BRYAN DONKIN a worldwide reputation for supply of safe, accurate and reliable equipment.

WWW.BRYANDONKINUSA.COM

BRYAN DONKIN USA Master Distributors

BURNER CONTROLS AND DESIGN
Territory: KS, MO, Southern IL

436 Anglum Road
Hazelwood, MO 63042
Tel (341) 993-5810
Fax (341) 993-4107
Email rogers@gobdc.com
Web www.gobdc.com

ETTER ENGINEERING COMPANY, INC.
Territory: New England, NY, NJ

210 Century Drive
Bristol, CT 06010
Tel 860-584-8842
Fax 860-584-8612
Email sales@etterengineering.com
Web www.etterengineering.com

BOILERROOM EQUIPMENT SALES
Territory: New York City, Long Island

120 Denton Avenue
New Hyde Park, NY 11040
Tel (516) 877-6300
Fax (516) 877-6303
Email rconstantino@bresales.com
Web www.bresales.com

MARSHALL W. NELSON and ASSOCIATES
Territory: MN, WI, ND, SD, MI (U.P.)

4300 N. Port Washington Road
Milwaukee, WI 53212
Tel (414) 332-6000
Fax (414) 332-2400
Email info@mwnelson.com
Web www.marshallwnelson.com

TRI-STATE METER and REGULATOR
Territory: TN

2865 Rudder Road
Memphis, TN 38118
Tel 800-365-1987
Fax (901) 365-6809
Email sales@tristatemeter.com
Web www.tristatemeter.com

WEEKS • WILLIAMS • DEVORE, INC.
Territory: NC, SC

222 Beltway Boulevard
Matthews, NC 28106
Tel 800-745-2999
Fax (704) 882-4111
Email kevin.hinson@wwdclt.com
Web www.wwd-inc.com